

DESIGNER series MODEL 45 DS DIMENSIONS

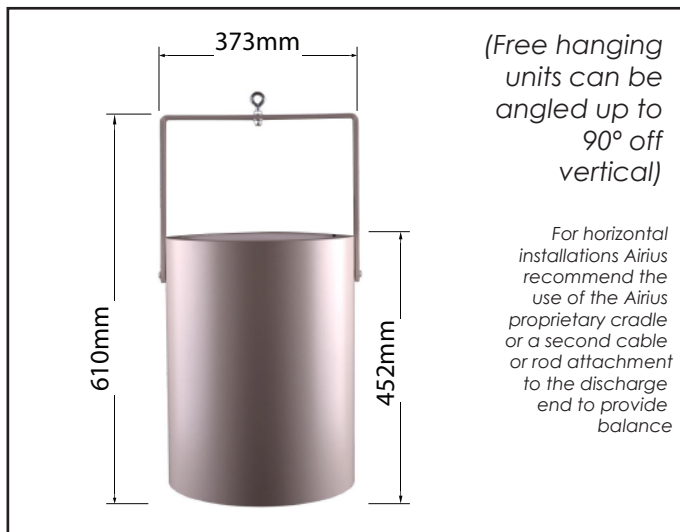

COVERAGE

- Ceiling Height
45/PS-2 = 12.5m - 14m
- Diameter
45/PS-2 = 15.5m - 10.5m
- Floor area
45/PS-2 = 167m² - 111m²

MOTOR

- Single Phase
- 45/PS-2 Motor = 2450 rpm @ 50hz
- PSC - Permanent Split Capacitor motor
- All model 45 motors are sourced by EBM PAPST

OPERATING TEMPERATURES

- Min start temp (approx.) = -10° C
- Min running temp = -20° C
- Shut off = 135° C
- Reset = 125° C

HOUSING

- Aluminium: powder coated off white
- Internal PC/ABS components 5VA flame rating

COLOUR

- Cool gray 2C - Off white as standard
- Can be tailor painted to your colour specifications

MODEL 45 DS PROPERTIES

UNIT SIZE	Standard
Weight:	8.6 kgs
Height to Rim:	457 mm
Total Height:	610 mm
Diameter:	373 mm

45/PS-2 MOTOR	230V
Watts* @ 50 htz:	125
RPM* @ 50 htz:	2450
L/S* @ 50 htz (m3/hr):	505 (1821)
AMPS* @ 50 htz:	0.54

*Motor data provided by motor manufacturer and is subject to change at anytime

INGRESS PROTECTION

- IP44 Rated

NOISE LEVELS

- Sound Power Level 78 dB(A)
- Sound Pressure Level @ 8 Mts 52 dB(A)
- Sound Pressure Level @ 12 Mts 48 dB(A)

Note: A typical free field environment over a reflecting plane.

* All acoustic testing undertaken at the EBM- Papst Acoustic Laboratories in Connecticut USA during August 2014

Please contact Airius for full Noise Testing Report

ACCESSORIES & OPTIONS

- Airius suspended ceiling kit - Allows Model 45 Airius unit to be mounted in a suspended ceiling grid
- Airius Transformer type speed controller 1 and 5 Amp available. 0-100% in 5 steps
- Airius speed control - TRIAC speed control to adjust top end RPM
- PHI kit - Photohydroionization - Advanced oxidation technology - Used to mitigate air contaminants

WARRANTY

- 5 years full manufacturers replacement from date of despatch. Subsequent 5 year 'half new price' rebuild cover

MODEL 45 DS PLACEMENT

PREPARATION

- Install electrical circuit(s) and outlet(s) in accordance with national and local electric codes
- Outlets should generally be mounted vertically unless a "twist/locking" type is being used
- Wall switch may be installed in circuit to disable power and prevent electrical hazards when servicing
- Confirm electrical continuity of Airius unit on the ground before permanently mounting in the ceiling

INSTALLATION

- Hang vertically as high in the ceiling as possible
Typically 300 – 450 mm from the roof deck to intake
- The Airius unit performs best when air column from the nozzle is unimpeded to the floor
- Use professionally installed hardware, capable of supporting a minimum of five times the weight
- Hardware to hang the unit includes but is not restricted to: Hooks, chains, cables, carabiners, bridle rings, beam clamps and bolts
- Density of the placement is directly related to the effectiveness, performance and savings
- Mount out of reach from people and animals
- Floor plans, mezzanines, office locations, machinery, people placement, plumbing, lighting, duct work, electrical systems, natural light/air systems, cranes, doors, windows, ventilation and fire suppression systems are all factors in properly locating the Airius system within the ceiling

NOTE:- Air Pears must not be installed directly to structure if they are to be angled. In this case a small length of cable or wire must be used between the handle and the structure to reduce compound twisting torque on the handle.

OPERATION

- Designed to operate 24 hours-a-day, 7 days-a-week to maintain thermal equalization/humidity equalization
- Use optional speed control to fine tune RPM if needed

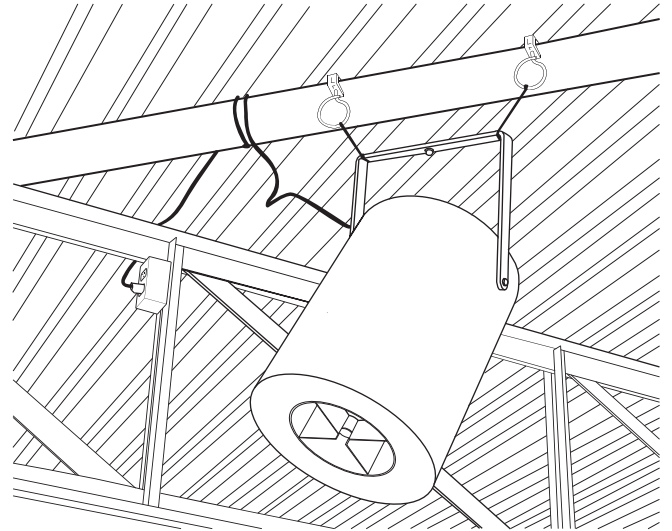

MAINTENANCE

- Frequency of cleaning will vary by application and environment
- You may clean the aluminium housing with a damp warm cloth, using mild household detergents
- Do not use petroleum products, thinners or solvents to clean any part of the Airius unit
- If the Airius unit fails, contact manufacturer

MATERIALS & PROPERTIES

- Constructed from recyclable materials
- The outer shell, stator and fan blades are fire rated 5VA materials
- Power cord is a 3 wire 1.02 mm diameter 300VAC rated electrical cord - CE/EU compliance rated as HO5VV
- Single phase, PSC - permanent split capacitor motor, single speed, axial motor
- Motor is thermally protected. Shutoff is at 135°C & reset is at 125°C
- 78 dB(A) Sound Power Level at 50 htz
- No lubrication required. Bearings are sealed



Airius LLC, © 2011. All Rights Reserved.