



# PRODUCT INFORMATION & INSTALLATION GUIDE 2021

Airius Model EC  
ONYX SERIES

[www.airius.com.au](http://www.airius.com.au)

**AIRIUS**<sup>®</sup>  
Airflow Reinvented

## MODEL EC DIMENSIONS AND PROPERTIES



<b>UNIT SIZE</b>	<b>STANDARD</b>
Weight:	7 kgs
Height to Rim:	343 mm
Total Height:	445 mm
Diameter:	368 mm
<b>MOTOR</b>	<b>230V @ 50 Hz</b>
Watts*:	87
RPM*:	1720
L/S*:	671
m <sup>3</sup> /hr:	2415
Centre Line Velocity <sup>1</sup> :	1.90 m/s @ 9 m
AMPS*:	1.30
Thrust*:	3 Newtons
<small>*Motor data provided by motor manufacturer and is subject to change at anytime  <sup>1</sup>Velocity profile tested in situ</small>	

### COVERAGE COOLING HEATING

Ceiling Height	= 5m - 8m	= 5m - 10m
Floor area	= Up to 60m <sup>2</sup>	= Up to 120m <sup>2</sup>

All data is indicative only and can change subject to application. For more accurate design please contact Airius Oceania

### MOTOR

Single Phase  
 Electrically commutated, variable speed 92% efficient motor  
 German EBM Papst EC motor  
 230 Volt @ 50/60 Hz

### OPERATING TEMPERATURES

Min start temp (approx.)	= - 10° C
Min running temp	= - 30° C
Shut off	= 110° C
Reset	= 90° C

### HOUSING

PC/ABS Resin - Inc. internal fixed blade stator  
 5VA flame resistance rating

### INGRESS PROTECTION

IP44 Rated

### NOISE LEVELS

Sound Power Level	= 74 dB(A)
Sound Pressure Level @ 3 mts	= 53 dB(A)
Sound Pressure Level @ 6 mts	= 46 dB(A)

Note: A typical free field environment over a reflecting plane.  
 All acoustic testing conducted at 230 Volt, 50Hz and undertaken at the EBM- Papst Acoustic Laboratories in Connecticut USA during August 2014

Please contact Airius for full Noise Testing Report

### COLOUR

Off white and black ABS plastic colours only available ex factory

If another colour required, an extra cost will be charged for spray painting the fan.

### ACCESSORIES & OPTIONS

- Multiple speed control options available:
- Full 0-100% potentiometer speed control option
  - Fully programmable Airius touch screen controller
  - Airius PearLink WiFi Control

Fully BMS controllable

Bacnet Protocol for individual fan control

For horizontal installations Airius recommend the use of the Airius proprietary cradle or a second cable or rod attachment to the discharge end to provide balance

### WARRANTY

5 years full manufacturers replacement from date of despatch.  
 Subsequent 5 year 'half new price' rebuild cover

## VELOCITY PROFILE

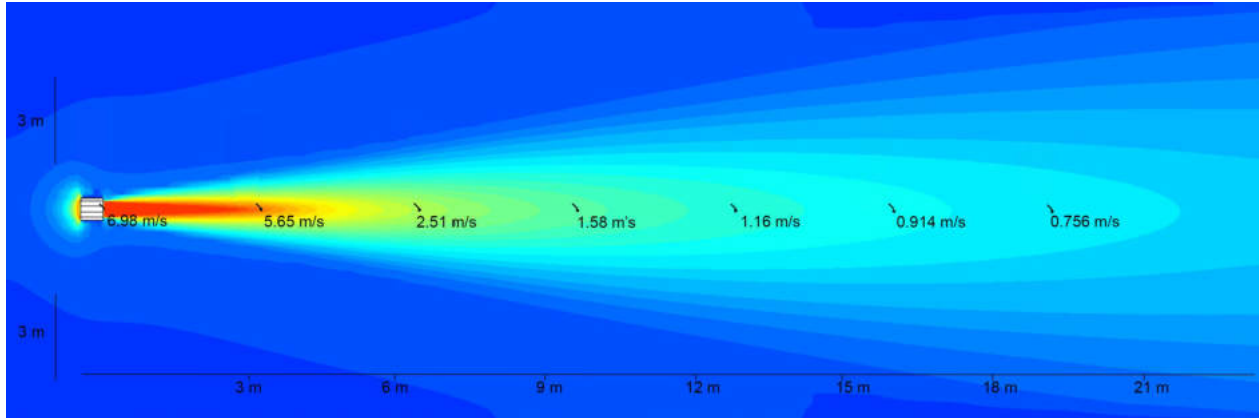

## UNIT PLACEMENT

### PREPARATION

Install electrical circuit(s) and outlet(s) in accordance with national and local electric codes.

Outlets should generally be mounted vertically unless a “twist/locking” type is being used.

Wall switch may be installed in circuit to disable power and prevent electrical hazards when servicing.

Confirm electrical continuity of Airius unit on the ground before permanently mounting in the ceiling.

### MAINTENANCE

Frequency of cleaning will vary by application and environment.

You may clean the plastic housing with a damp warm cloth, using mild household detergents.

Do not use petroleum products, thinners or solvents to clean any part of the Airius unit.

If the Airius unit fails, contact manufacturer.

### MATERIALS & PROPERTIES

Constructed from recyclable materials.

The outer shell, stator and fan blades are fire rated 5VA materials.

Power cord is a 1.8m, 3 wire, 1.02 mm diameter 300VAC rated electrical cord - CE/EU compliance rated as HO5VV (PLUG NOT SUPPLIED).

Electrically commutated, variable speed 92% efficient motor.

Motor is thermally protected. Shutoff is at 110°C & reset is at 90°C.

No lubrication required. Bearings are sealed.

### OPERATION

Designed to operate 24 hours-a-day, 7 days-a-week to maintain air circulation/thermal equalization/humidity equalization.

Use optional speed control to fine tune RPM if needed.

### INSTALLATION

Do not hard connect fans in excess of 10 kgs unless agreed with Airius prior to Installation. When attaching it is preferred if some chain or cable is used between fan and the support. However it is not imperative.

For Cooling the Airius fan should be located to suit client's requirements. Suggested locations are from just under the ceiling or closer to the floor to ensure suitable air-cooling flow.

For Heating or Conditioned Spaces the Airius fan should be securely installed as close as possible to the ceiling.

For combination applications fans can be installed close to ceiling or lowered slightly. Contact Airius for design details and assistance.

The Airius unit performs best when air column from the nozzle is unimpeded to the floor.

The Airius unit should not be mounted directly in front of heat ducts, vents or any other high heat source.

Use professionally installed hardware, capable of supporting a minimum of five times the weight of the fan unit.

Hardware to hang the unit includes but is not restricted to: Hooks, chains, cables, carabiners, bridle rings, beam clamps and bolts.

Density of the placement is directly related to the effectiveness, performance and savings.

Mount out of reach from people and animals.

Floor plans, mezzanines, office locations, machinery, people placement, plumbing, lighting, duct work, electrical systems, natural light/air systems, cranes, doors, windows, ventilation and fire suppression systems are all factors in properly locating the Airius system within the ceiling.

## CHAIN HUNG (STRAIGHT)

PLUG NOT SUPPLIED

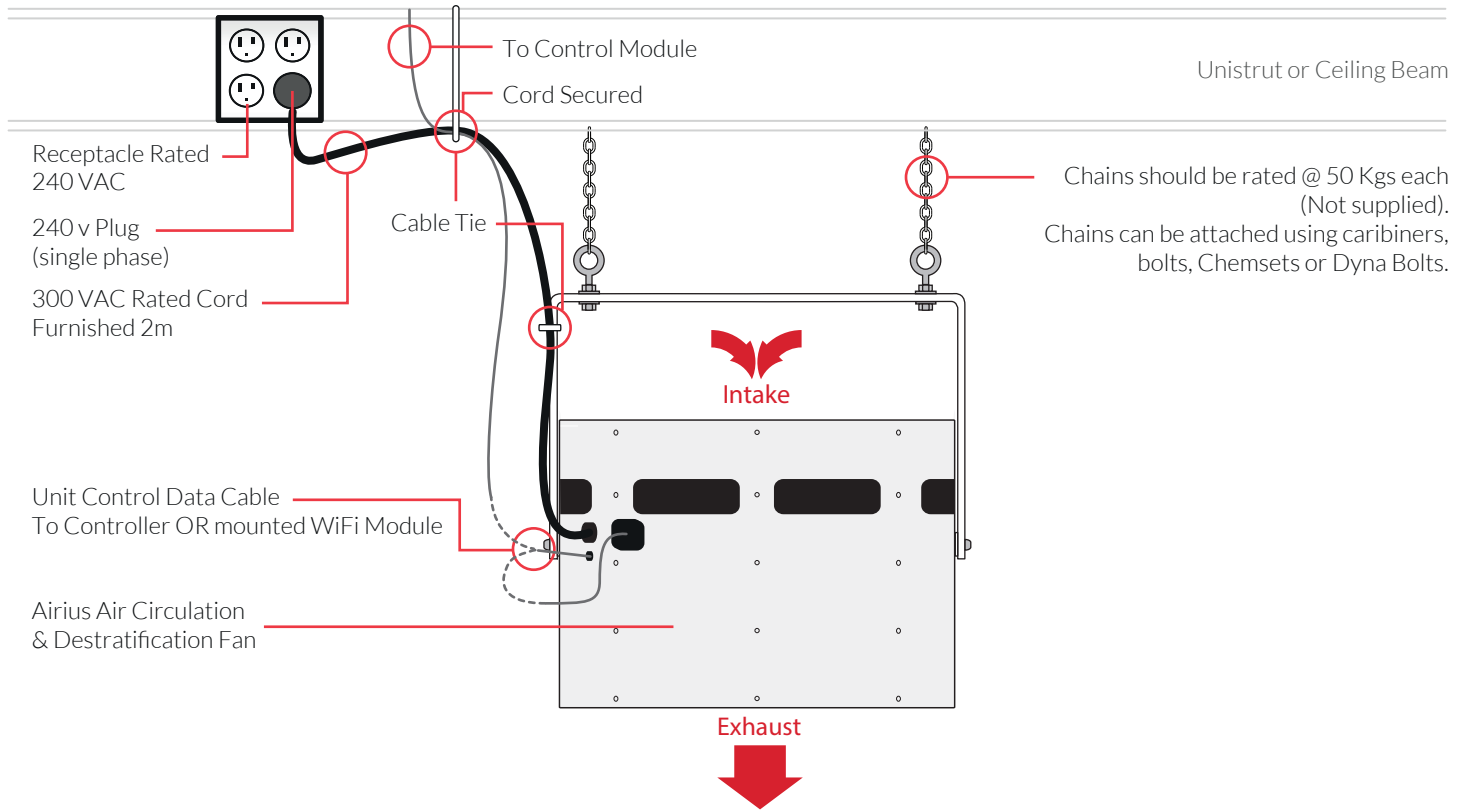

## CEILING FIXED (STRAIGHT)

PLUG NOT SUPPLIED

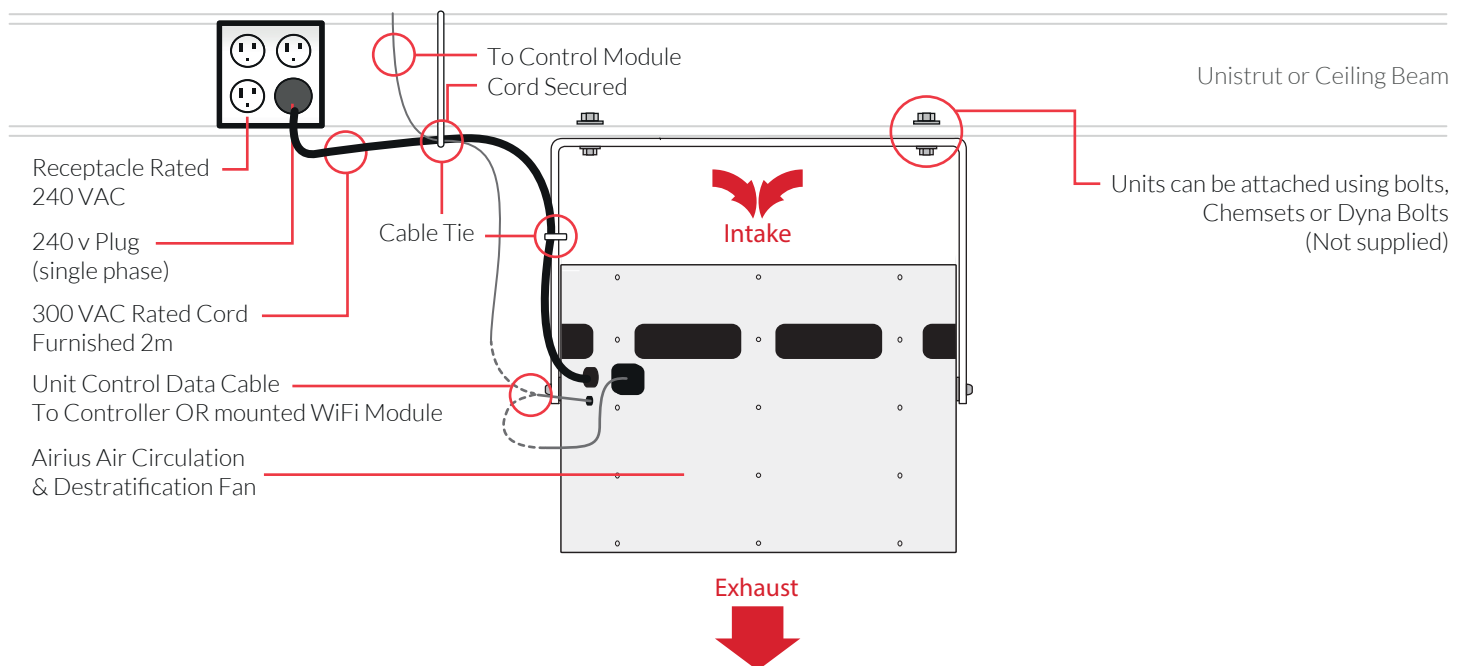

**WALL FIXED (STRAIGHT)**

PLUG NOT SUPPLIED

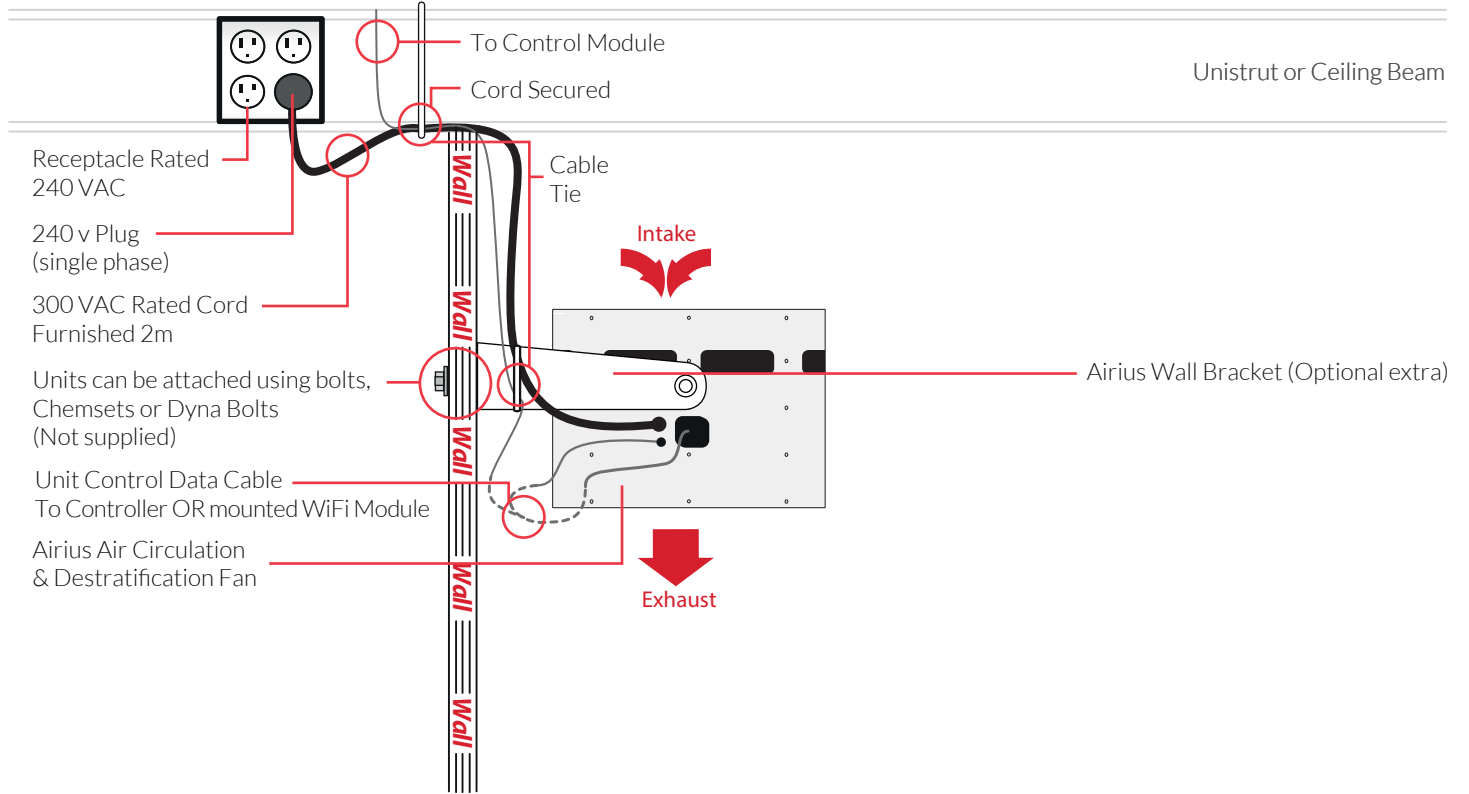

### CHAIN HUNG (ANGLED)

PLUG NOT SUPPLIED

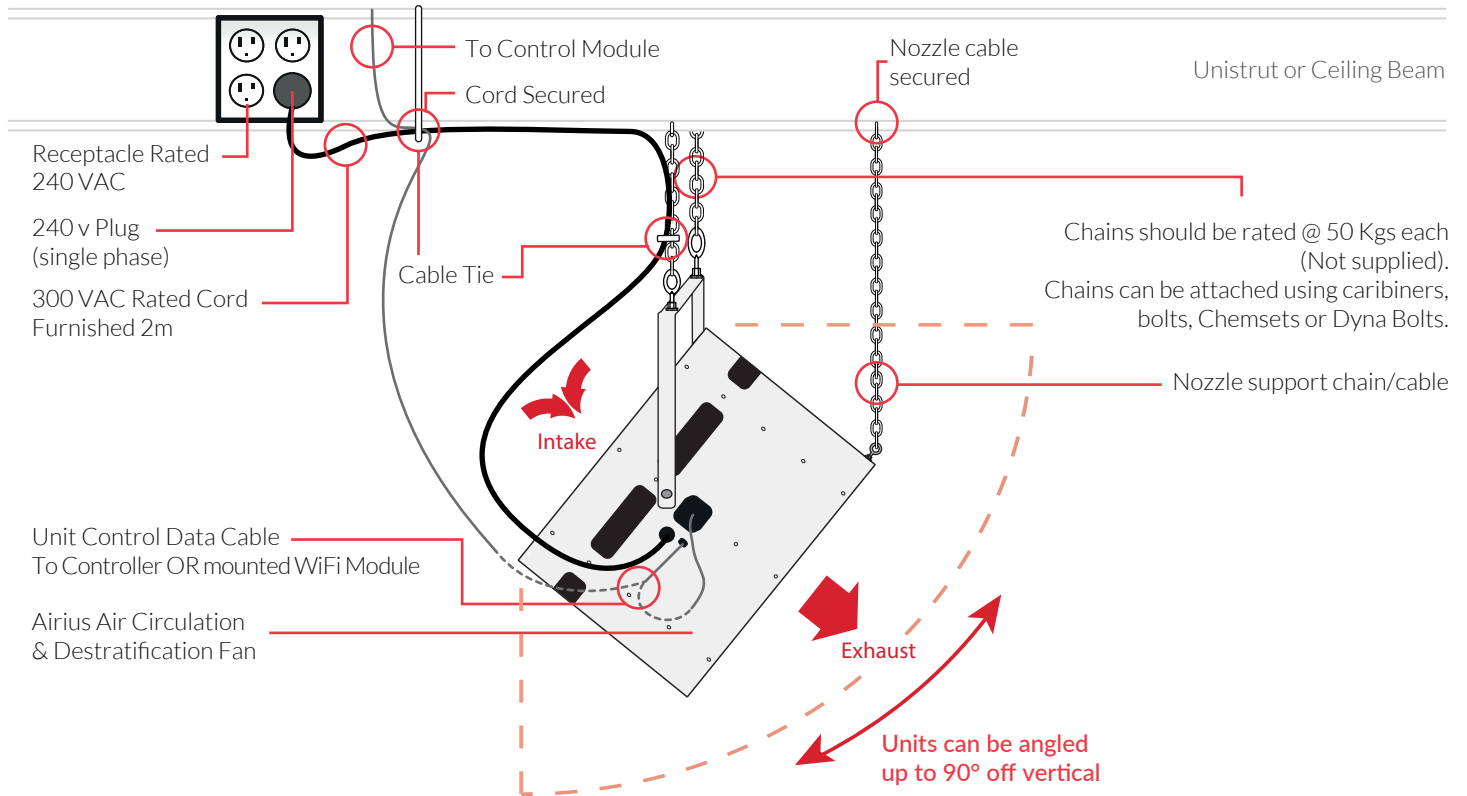

### CEILING HUNG (ANGLED)

PLUG NOT SUPPLIED

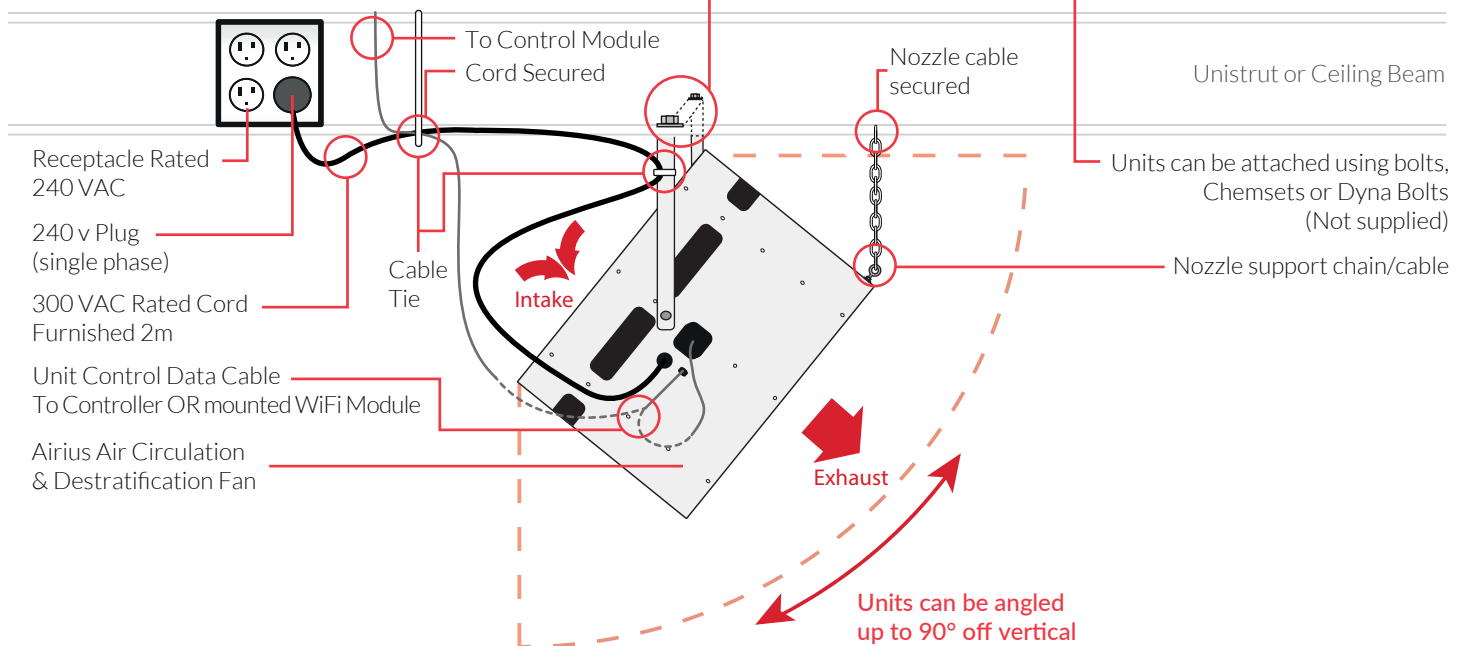

**WALL FIXED (ANGLED)**

PLUG NOT SUPPLIED

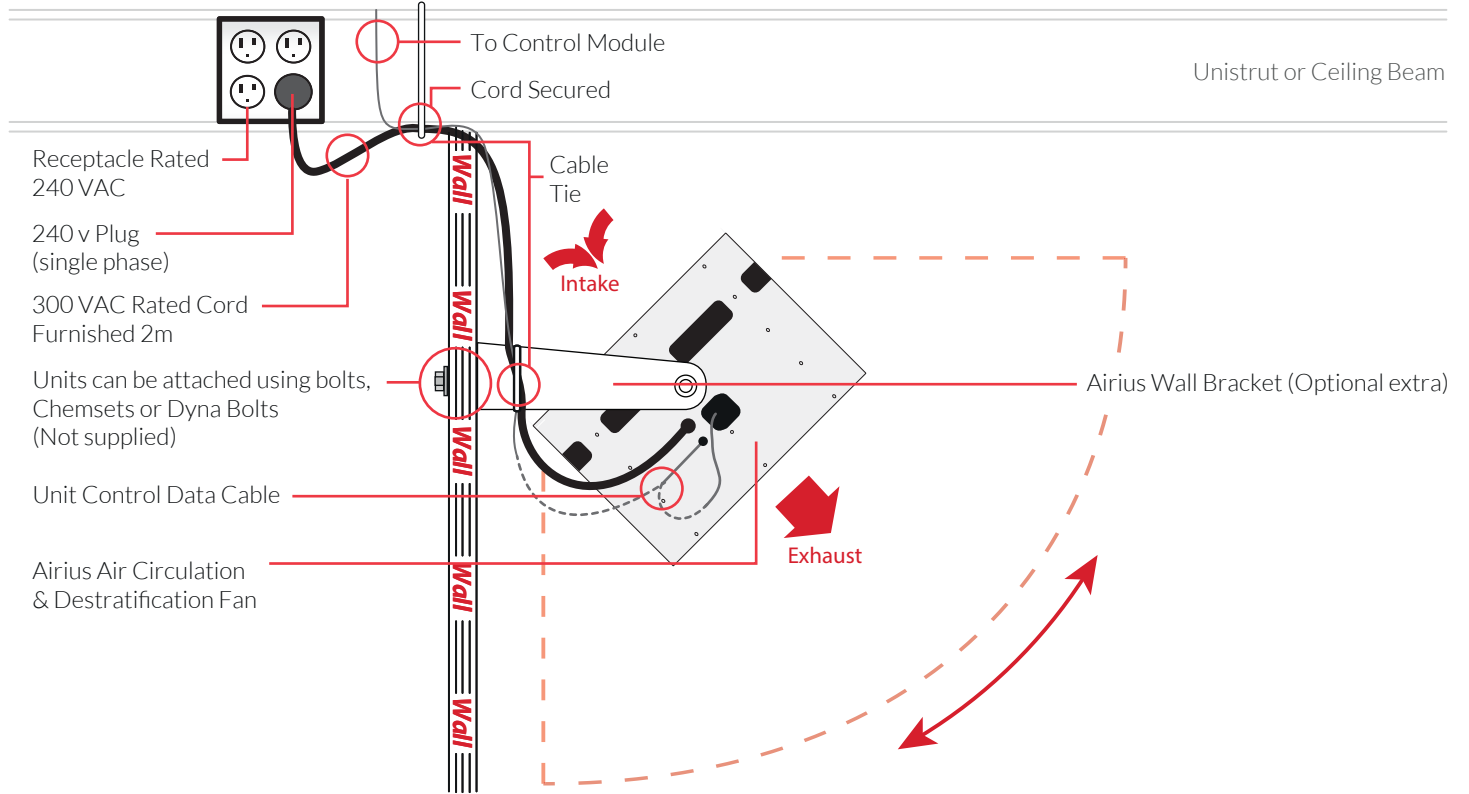



# 0-10V Potentiometer

## Wall Mounted



- 10k pot for controlling a 0-10V analogue control input on an EC fan or a VSD that is being used on an AC fan.
- On/Off Switch that switches the digital enable signal from a EC fan or VSD
- Uses HPM Excel wallplate with a removable knob.

Part no. 10KPot



## Speed Control Pot

The 10k pot is designed to connect to an analogue 0-10V control signal from a EC fan or VSD being used to control an AC fan. Adjusting this pot will vary the fan speed.

The resistance of the pot is 10k and it has a linear curve (ie the resistance at 10% is 1k, 50% is 5k, 75% if 7.5k, etc).

Please note the "0V" is to be connected to the 0V or GND terminal of the EC motor/VSD, not the Earth.

## WARNING

The 10k pot and on/off switch is only for use with a 0-10V control signal and digital enable signals - do NOT connect it in anyway with a the 240V/415V power source of the fan or VSD.

## Switch

To turn On/Off an EC fan or VSD the digital enable input should be used. The 240V/415V power input to the fan or VSD should be kept powered and not used to turn the fan on/off.

This allows the electronics in the EC fan or VSD to gently stop the motor and power down the electronics - increasing their life.

Turning the EC fan or VSD on/off via the 240V/415V power can damage the electronics due to inrush currents which in turn will reduce the life of the EC fan or VSD

## Wiring Diagrams

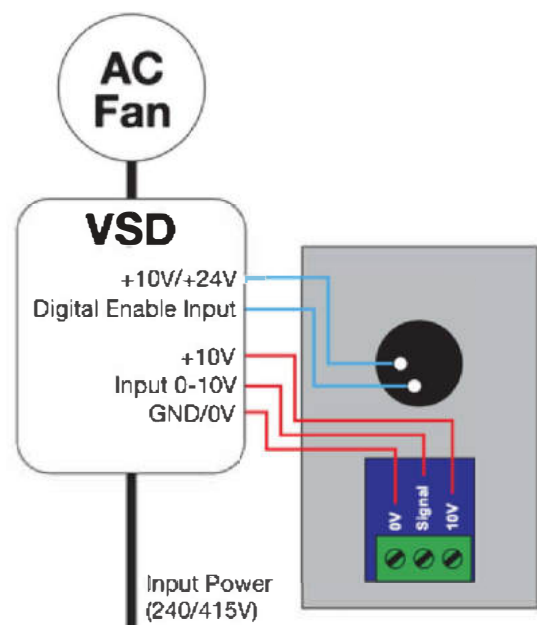
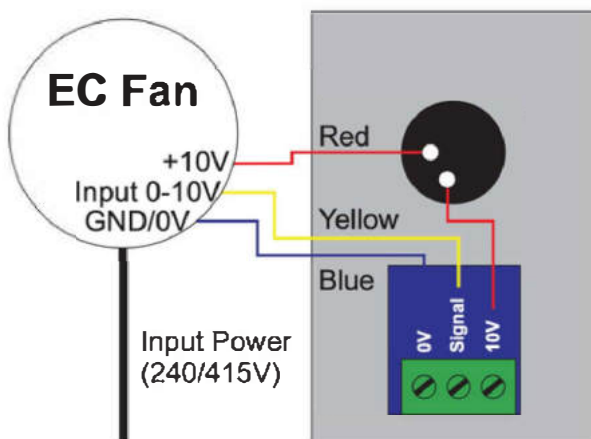

## BMS CONTROL WIRING

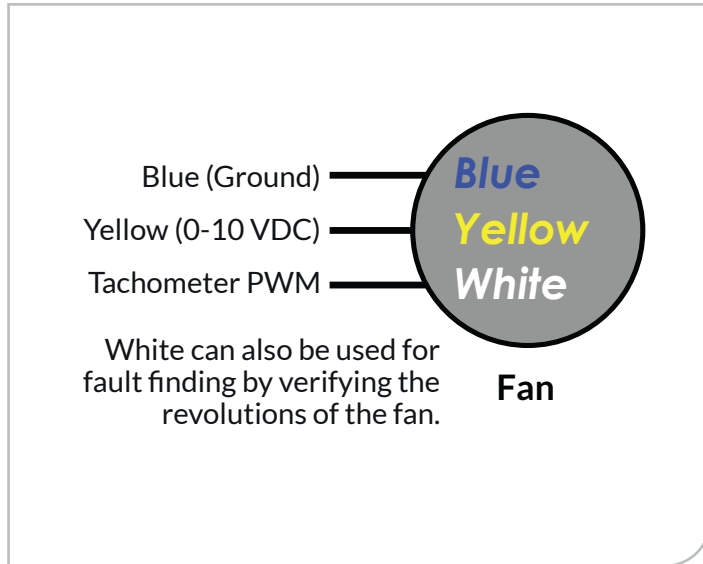

### GENERAL NOTES

- 0-10 V signal allows infinitely variable open loop speed control
- Connecting the red and yellow leads will allow EC fans to operate at full speed
- A single controller can be used to control multiple fans with the same speed setting
- The BMS generates this voltage to send to the signal (yellow)
- Yellow is labelled as 0-10VDC because that is the acceptable range of voltages that the fan will accept

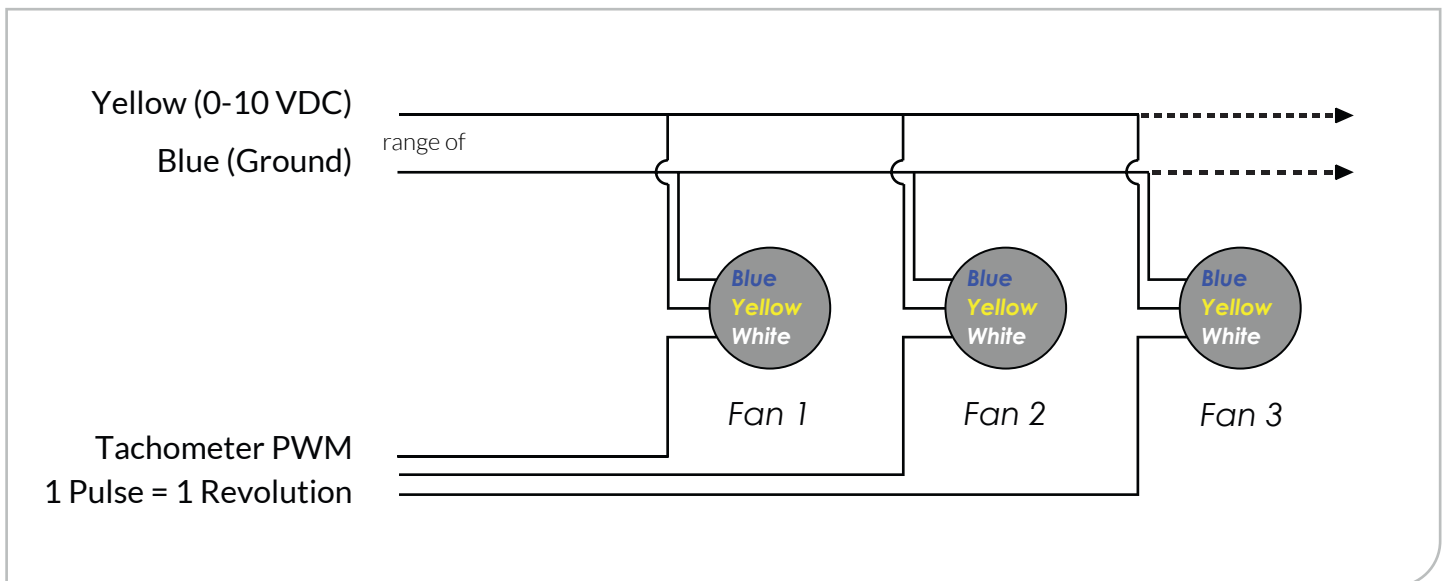

## TOUCH SCREEN EC FAN CONTROLLER



### SPECIFICATIONS

Operating voltage	24V DC ONLY (By Others)
Mounting	Surface mount backbox option
Display	3.5" Resistive touch-screen 320x240 pixel resolution 65k colours
Operating Temp	5..50oC
Storage Temp	-25..+75oC
Relative Humidity	%5..95 rh, non-condensing
Weight	165gr ( 225 gr with packaging )
Protection	IP30 according to EN 60529
Connections	Screw terminals, max 1 mm <sup>2</sup> (26-16 AWG)
Programming Port	Standard Micro USB cable

### CONTROLLER DESCRIPTION

#### Overview

The Airius Touch Screen Controller is a programmable room controller ideal for managing Airius EC fans.

The unit has no on-board inputs & outputs, but is able to connect to a multitude of external IO, due to multiple communication ports and protocols. Integrated temperature sensor is standard.

#### Display / User Interface

3.5" resistive color touch-screen. 65K colors.

#### Powered by SEDONA Framework

The Sedona Framework™ provides a complete software platform for developing, deploying, integrating, and managing pervasive device applications at the lowest level.

It brings the power of programmable control and the Internet down to extremely inexpensive devices.

The Sedona Framework distributes decision making control and manageability to any device and brings intelligence and connectivity to the network edge and back.

## INPUT OUTPUT MODULE FOR AIRIUS TOUCH SCREEN CONTROLLER

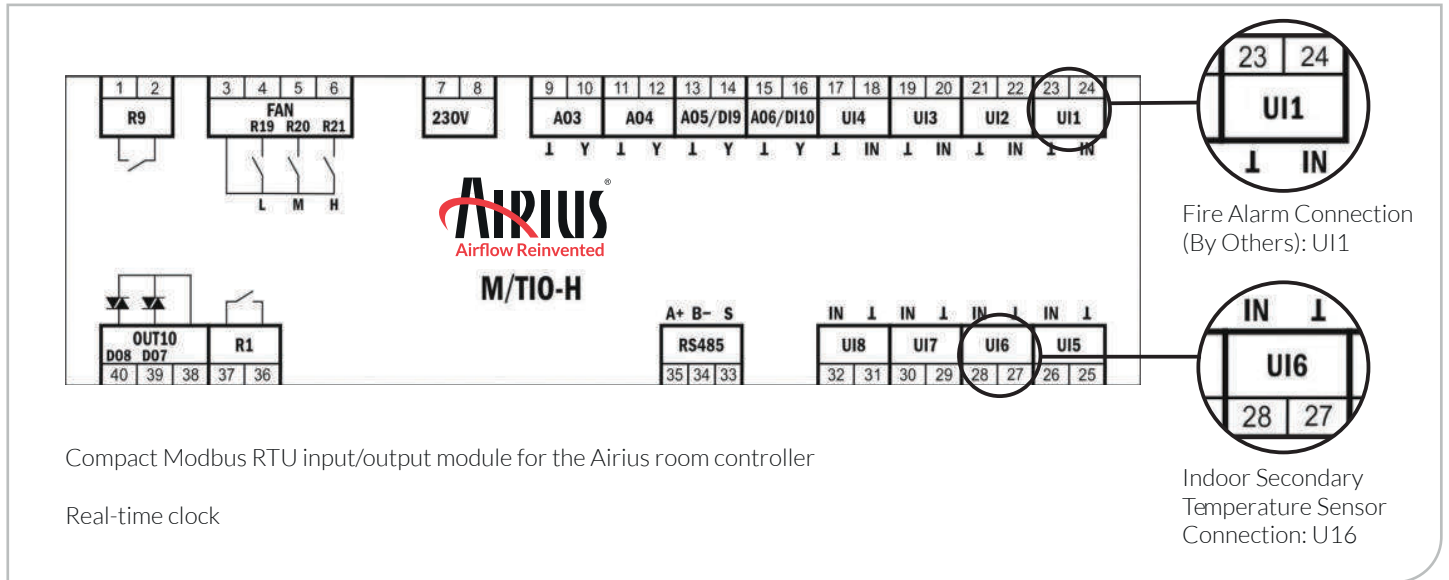

### SPECIFICATIONS

Operating voltage	230V DC +10% -5%, 50/60Hz
Power Consumption	Max 3.5 VA (including Airius touch screen, excluding field devices)
Operating Temp	5..50oC
Storage Temp	-25..+75oC
Weight (net/gross)	400 gr / 530 gr 750 gr / 890 gr (aux. 24V DC output versions)
Dimensions	158 x 86 x 60 mm
Installation	Standard 35 mm rail mount
Protection	IP30 according to EN 60529
Connections	Screw terminals, max 1.5 mm <sup>2</sup> (AWG 16)
Universal Inputs	8 inputs (see table for sensor signal compatibility)
Relay Output	4 Relays, 230 V DC / 5A 1 Relay, 230 V DC / 10A
Triac Outputs	2 Triacs, 0.1A@230V DC 0.5A@24V DC
Modulating Outputs	4 outputs 0(2)-10 VDC, 2mA max (2 configurable as digital in)
Expansion Port	Ribbon cable connection to max 2 relay module (RK4)

### DIMENSIONS

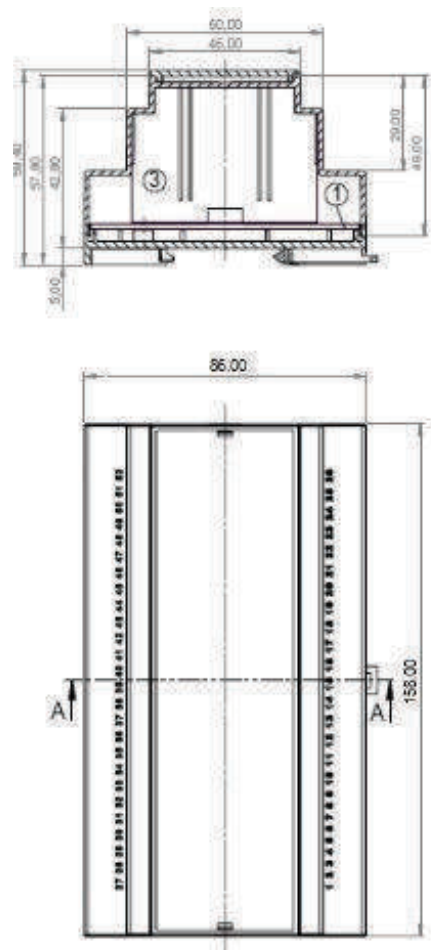

## CONNECTIONS

### M/TIO DESCRIPTION

#### General

M/TIO modules provide a compact input/output solution for Modbus RTU master controllers.

The unit has incredibly flexible input / output configuration that allows many applications to be controlled by a single device.

A combination with any Modbus wall unit greatly simplifies installation on the wall-unit side, as the IO module can be located close to the terminal unit being controlled, with only communication wiring into the wall unit. The mains powered versions eliminate the need for additional power supplies or transformers further reducing cost and installation labor.

M/TIO also hosts a battery backed-up real-time-clock..

#### Relay Outputs

5 relay outputs are provided. Each relay can be used independently, and a specific set of three can be configured for 3-speed fan control.

#### Universal Inputs

8 inputs are provided, configurable as below:

	Pt1000	NTC	0-19 VDC	Voltage Free Contact
In 1		✓		✓
In 2		✓		✓
In 3		✓		✓
In 4		✓		✓
In 5	✓			✓
In 6	✓		✓	✓
In 7	✓		✓	✓
In 8	✓		✓	✓

#### Triac Outputs

2 triac outputs are provided with flexible configuration options, allowing control of on/off thermoelectric (PWM) or floating actuators or relays. The triacs can be independently configured to control different loads. However, due to internal connections, all loads must be supplied from the same AC voltage. Floating (three-position) configuration requires use of both triacs.

#### Modulating Outputs

Four 0-10VDC analog outputs are provided for controlling modulating valve or damper actuators. Two of these can be configured to function as digital inputs.

#### Expansion Port

Up to two RK4 modules can be connected to the device with a ribbon cable, providing a total of 8 additional relay outputs

#### Real Time Clock

4 time-schedules can each be independently associated with a relay output through configuration parameters. Each schedule allows 28 sets of start/stop times per day of the week.

WIRING DIAGRAM - 4 OR 8 FANS OR GROUPS OF

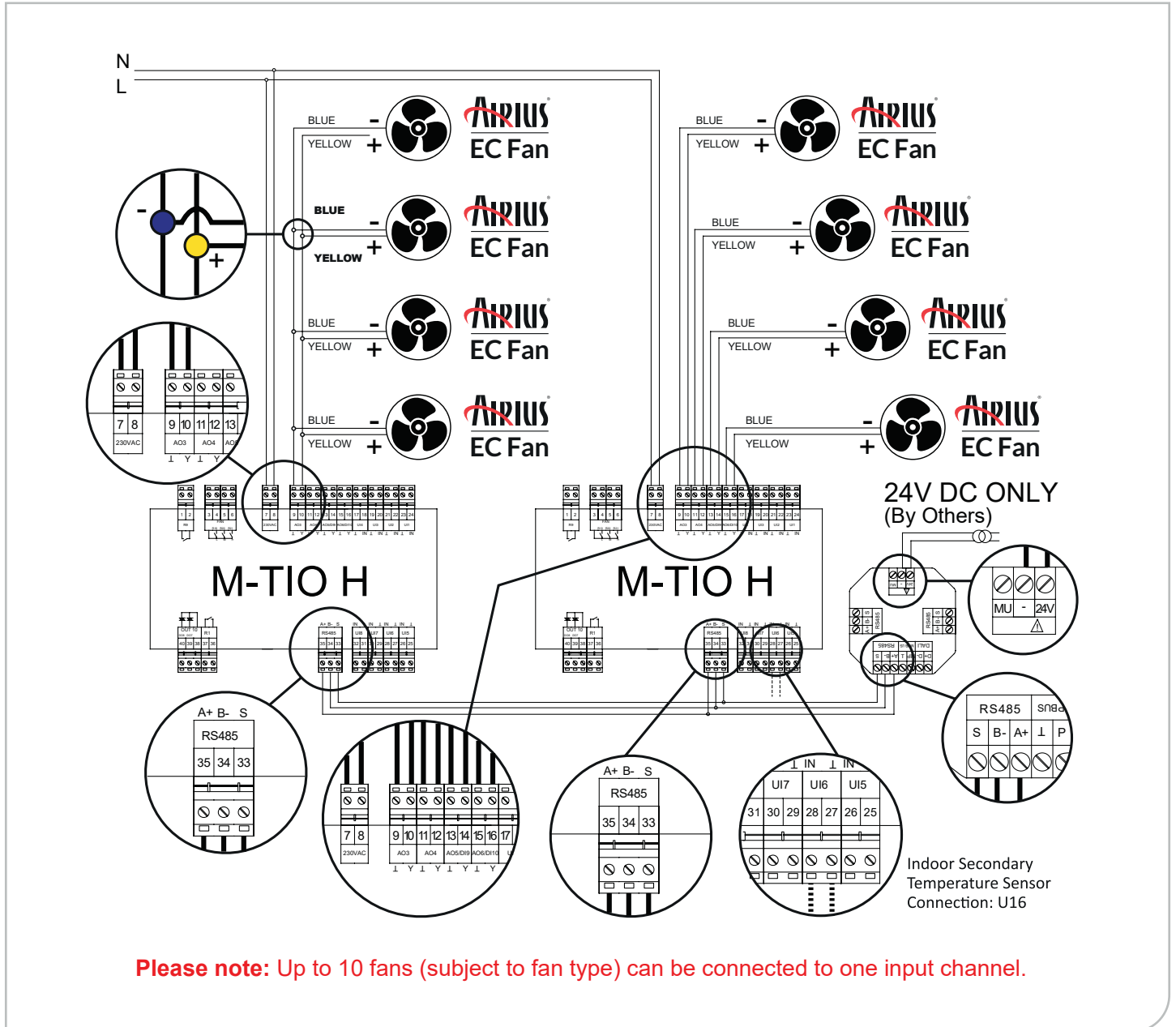

**AIRIUS TOUCH SCREEN CONTROLLER WITH FIRE ALARM INPUT (BY OTHERS)  
AND EXT TEMP SENSOR - 4 FANS**

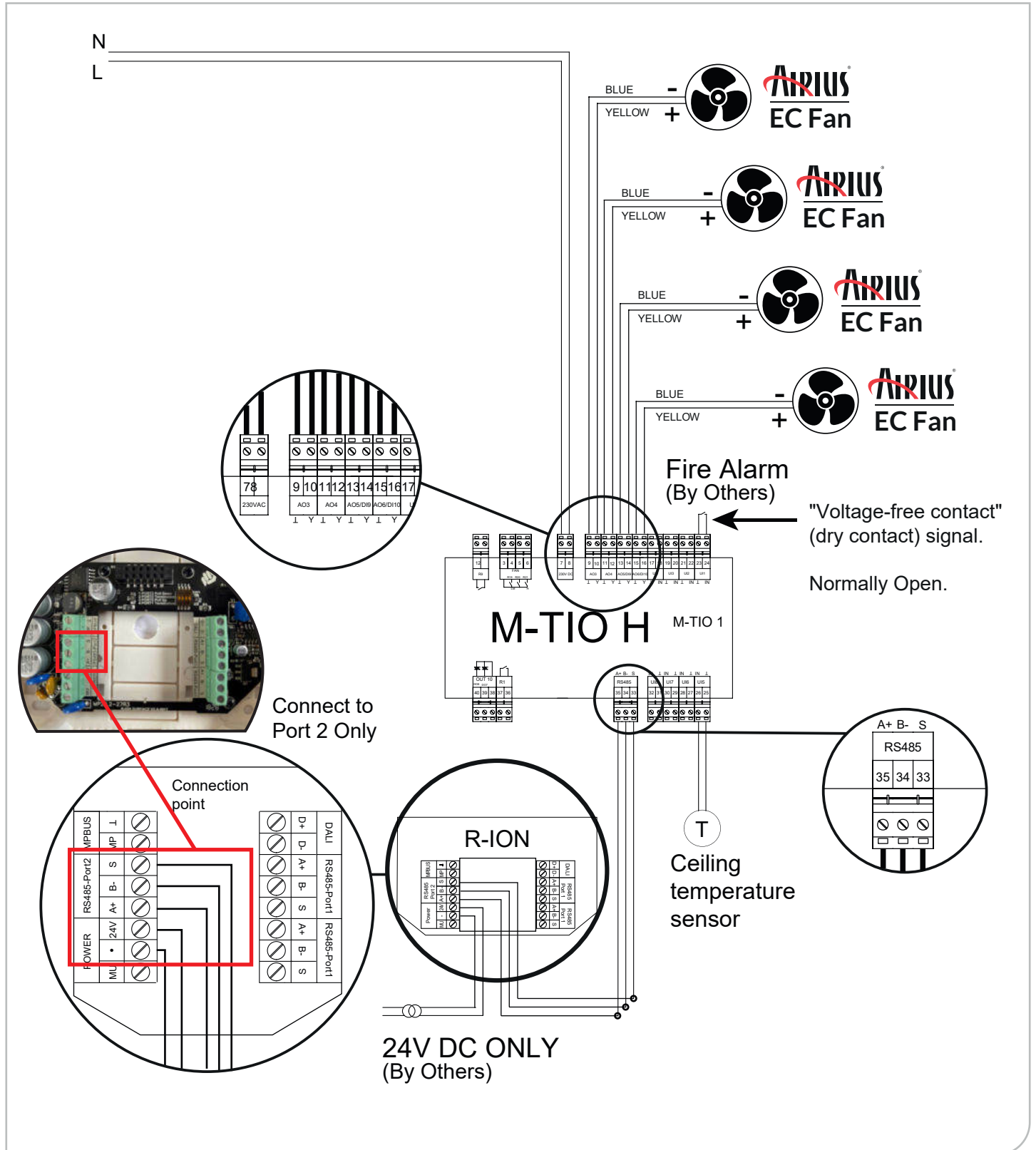



**AIRIUS TOUCH SCREEN CONTROLLER WITH FIRE ALARM INPUT (BY OTHERS)  
 AND EXT TEMP SENSOR - 8 FANS**

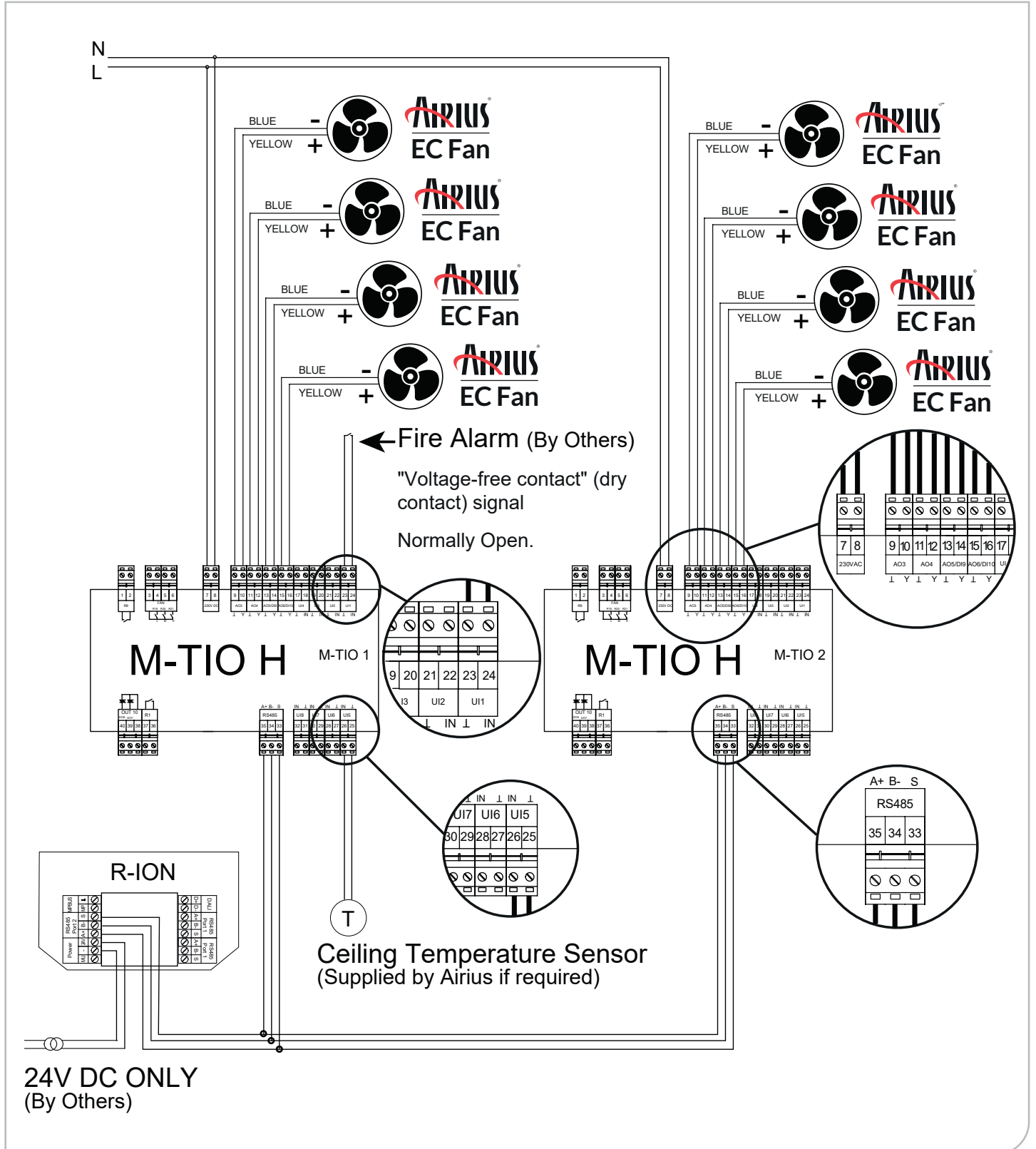

## STANDARD WALL BOX INSTALLATION

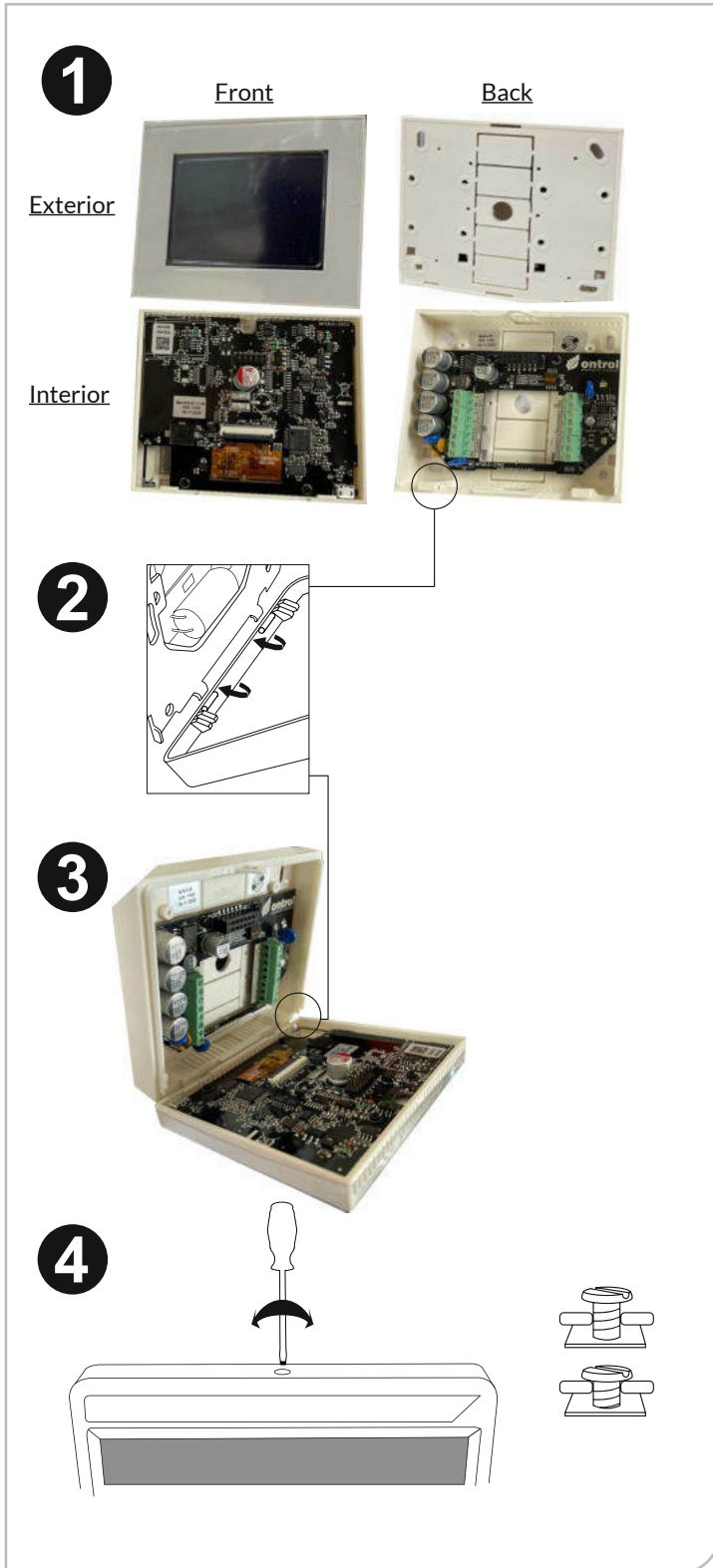

Fit base unit in flush-mounted box.  
Fasten metal frame to wall box with two screws\*.

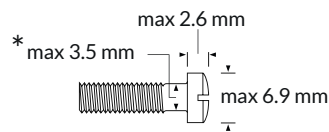

Fit display unit's bottom side on the metal frame's hinges.

Rotate display unit up on to the base unit, making sure connection pins are aligned.

Tighten captive top screw with small screw-driver.



**When removing display part**

- Make sure to untighten the top fixing screw
- Pull only from the top, with two fingers on the sides
- Do not apply excessive force

## INSTALLATION TIPS

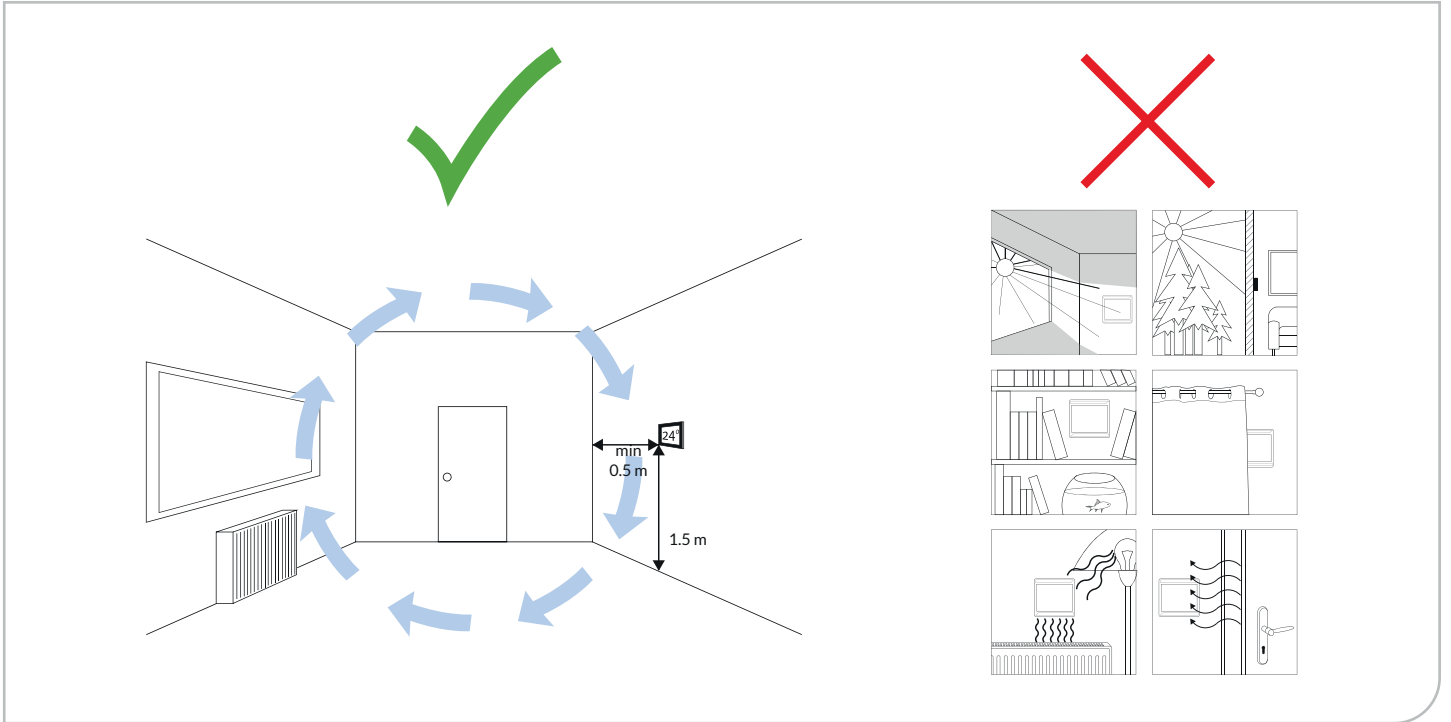



**AIRIUS**<sup>®</sup>

Airius (Oceania) Pty Ltd

P.O. Box 1812, Byron Bay, NSW 2481

[info@airius.co.au](mailto:info@airius.co.au)

[www.airius.com.au](http://www.airius.com.au)